

Series
VENTS VUT EH



A8 control panel

Air handling units with the air capacity up to **2200 m³/h** and heat recovery efficiency up to 88% in sound-proof and heat-insulated casing with electric heater

■ **Description**

Air handling units VUT EH with electric heater and VUT WH with water heater are the complete air handling units designed to provide both supply and exhaust ventilation with air filtering and heat recovery. The exhaust air energy is used to heat up the supply fresh air through the heat exchanger. All the models are designed for connection with Ø 125, 150, 160, 200, 250, 315 mm round ducts.

■ **Modifications**

VUT EH – a range of compact energy saving air handling units (AHU) equipped with supply and exhaust centrifugal fans, cross-flow heat exchanger, electric heater and air filters.

VUT WH – a range of compact energy saving air handling units (AHU) equipped with supply and exhaust centrifugal fans, cross-flow heat exchanger, water or glycol heater and air filters.

■ **Casing**

The casing is manufactured from aluminum-zinc compound with 25 mm thick mineral wool heat- and sound-insulating layer.

Designation key:

Series	Rated air capacity [m ³ /h]	Heater type	Duct connection	Row number of the heater	Service side (for VUT 1500 WH, VUT 2000 WH)
VENTS VUT	350; 500; 530; 600; 800; 1000; 1500; 2000	E – electric W – water	H – horizontal	2 – two rows; 4 – four rows	L – left side R – right side

Accessories



page 368

page 368

page 412

page 430

page 435

page 443

page 440

page 484

page 485

page 329

Series
VENTS VUT WH



A13 control panel

Air handling units with the air capacity up to **2100 m³/h** and heat recovery efficiency up to 78% in sound-proof and heat-insulated casing with water heater

■ **Filter**

Two incorporated G4 panel filters for extract air ventilation and F7 filters for supply air ventilation are supplied with the unit.

■ **Fans**

The units are equipped with supply and exhaust centrifugal double-inlet fans with forward curved blades and built-in thermostat with automatic restart. The electric motors and impellers are dynamically balanced in two planes. The ball-bearings used with motors are designed for at least 40 000 hours operation and are maintenance-free.

■ **Heat exchanger**

The heat exchangers have high efficiency and are manufactured from aluminium plates. The unit is also equipped with the drain pan for condensate drainage.

■ **Heater**

The electric heater (for the unit VUT EH) or the water heater (for the unit VUT WH) at outlet from the heat exchanger is designed for warming up of supply air up to the set level if heat recovery is not enough

to attain the set supply air temperature. The water heaters are designed for max. operating pressure 1.0 MPa (10 bar) and max. heat medium operating temperature 95 °C.

■ **Automation and control system**

The unit incorporates an integrated automation and control system with a multi-functional control panel with LCD display. The standard delivery set includes 10 m connection cable for connection to the remote control panel. The unit has the freezing protection function to prevent the heat exchanger freezing by means of actuating the bypass damper and controlling water heater. As the temperature sensor warns of the freezing danger, the bypass air damper is opened and the intake air is directed through the air duct beside the heat exchanger. As the heat exchanger is warmed the supply air temperature rises up to the set level while passing through the heater. Meanwhile the warm extract air warms up the heat exchanger. After the freezing danger is no longer imminent, the bypass damper shuts the bypass duct and the unit reverts to the standard operation mode.

■ **VUT EH control and protection functions**

- ▶ control from the control panel: switching on/off, speed selection, timer, faults;
- ▶ maintaining the set room temperature by the sensor on the control panel – smooth heating capacity control;
- ▶ three-speed fan speed control (low-medium-high);
- ▶ unit operation according to daily and week schedule (timer adjustable from the control panel);
- ▶ safe start-up/shutdown of the fans;
- ▶ electric heater overheating protection by the temperature sensor installed in the supply air duct and by two overheating thermostats, one thermostat activated at 60 °C with automatic reset and another thermostat activated at 90 °C with manual reset. Blowing of the heating elements for heat removing at the end of the heating cycle;
- ▶ filter clogging control by engine hours.

■ **VUT WH control and protection functions**

- ▶ control from the control panel: switching on/off, three-speed fan selection, selecting heating/cooling modes (if connected to duct heater); room temperature display;

- ▶ maintaining supply air temperature set from the control panel by controlling the circulation pump and actuating the heat medium regulating valve; input from the heat medium flow switch (pump alarm);
- ▶ safe start-up/ shutdown of the fans, warming up of the water heater before start-up; return heat medium temperature control when the fan is off;
- ▶ freezing protection of the water heating coils by the exhaust temperature sensor and the return heat medium temperature sensor;
- ▶ control of the compressor and condensing unit of the water cooler by the room temperature sensor (for the models equipped with a duct air cooler);
- ▶ actuating the external air dampers with a return spring;

- ▶ unit operation according to week schedule (set at the system setup);
- ▶ unit shut down at signal from the fire alarm system;
- ▶ smooth bypass damper control in the bypassing mode to prevent the heat exchanger freezing.

■ Mounting

The unit is designed for indoor mounting. While mounting the unit provide the correct condensate collection and drainage. Access for the unit servicing and filter cleaning is from the side panels on the left from supply air side.

Access for the unit servicing for VUT 1500 WH and VUT 2000 WH is available from the left or right side panels depends on order code.

■ Options

For attenuation of sound generated by the fans it is recommended to install the duct silencer (refer SR) from inside before the unit. For vibration absorbing it is recommended to install the flexible anti-vibration connectors (refer VVG) on both sides of the unit. The mixing units USWK are recommended for smooth supply air temperature regulation in the units equipped with water heaters. The mixing unit USWK with three-way heat medium regulating valve and circulation pump provides smooth heating capacity regulation and minimizes the water heater freezing danger.

Unit overall dimensions:

Type	Dimensions, [mm]											
	∅D	B	B1	B2	B3	H	H1	H2	H3	L	L1	L2
VUT 350 EH	124	497	403	248	348	554	–	111	230	954	996	1054
VUT 500 EH	149	497	403	248	348	554	–	111	230	954	996	1054
VUT 530 EH	159	497	403	248	348	554	–	111	230	954	996	1054
VUT 600 EH	199	497	403	248	348	554	–	111	230	954	996	1054
VUT 800 EH	249	613	460	306	386	698	832	154	280	1071	1117	1171
VUT 800 WH	249	613	460	306	386	698	832	154	280	1071	1117	1171
VUT 1000 EH	249	613	460	306	386	698	832	154	280	1071	1117	1171
VUT 1000 WH	249	613	460	306	386	698	832	154	280	1071	1117	1171
VUT 1500 EH	314	842	581	320	520	814	947	201	595	1345	1388	1445
VUT 1500 WH	314	842	581	320	520	814	947	201	595	1345	1388	1445
VUT 2000 EH	314	842	581	320	520	814	947	201	595	1345	1388	1445
VUT 2000 WH	314	842	581	320	520	814	947	201	595	1345	1388	1445

Accessories for air handling units:

Type	Replaceable filter (panel filter) G4	Replaceable filter (panel filter) F7
VUT 350 EH	SF VUT 300-600 EH/WH G4	SF VUT 300-600 EH/WH F7
VUT 500 EH		
VUT 530 EH		
VUT 600 EH		
VUT 800 EH		
VUT 1000 EH	SF VUT 1000 EH/WH G4	SF VUT 1000 EH/WH F7
VUT 1500 EH	SF VUT 2000 EH/WH G4	SF VUT 2000 EH/WH F7
VUT 2000 EH		
VUT 800 WH-2	SF VUT 1000 EH/WH G4	SF VUT 1000 EH/WH F7
VUT 800 WH-4		
VUT 1000 WH-2		
VUT 1000 WH-4		
VUT 1500 WH-2		
VUT 1500 WH-4	SF VUT 2000 EH/WH G4	SF VUT 2000 EH/WH F7
VUT 2000 WH-2		
VUT 2000 WH-4		
VUT 2000 WH-4		

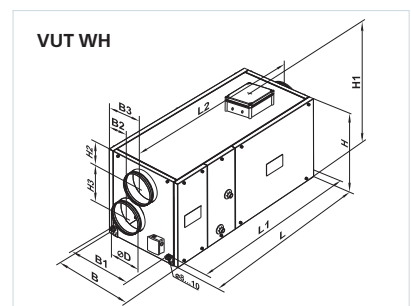
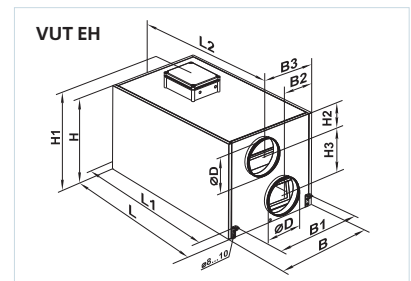

VENTS
AIR HANDLING UNIT WITH
HEAT RECOVERY SERIES
VUT EH / WH

AIR HANDLING UNITS WITH HEAT RECOVERY

Technical data:

	VUT 350 EH	VUT 500 EH	VUT 530 EH
Voltage [V / Hz]	1~ 220-240 / 50-60	1~ 220-240 / 50-60	1~ 220-240 / 50-60
Maximum fan power [W]	2pcs. x 130	2pcs. x 150	2pcs. x 150
Fan current [A]	2pcs. x 0.60	2pcs. x 0.66	2pcs. x 0.66
Electric heater power [kW]	3	3	4
Electric heater current [A]	13	13	17.4
Number of water (glycol) coil rows	-	-	-
Total unit power [kW]	3.26	3.3	4.3
Total unit current [A]	14.2	14.32	18.72
Air capacity [m ³ /h]	350	500	530
RPM	1150	1100	1100
Noise level at 3m [dBA]	24-45	28-47	28-47
Transported air [°C]	-25 up to +55	-25 up to +50	-25 up to +50
Casing material	aluzinc	aluzinc	aluzinc
Insulation	25 mm mineral wool	25 mm mineral wool	25 mm mineral wool
Extract filter	G4	G4	G4
Supply filter	F7 (EU7)	F7 (EU7)	F7 (EU7)
Connected air duct diameter [mm]	∅ 125	∅ 150	∅ 160
Weight [kg]	45	49	49
Heat recovery efficiency	up to 78%	up to 88%	up to 88%
Heat exchanger type	cross-flow type	cross-flow type	cross-flow type
Heat exchanger material	aluminum	aluminum	aluminum

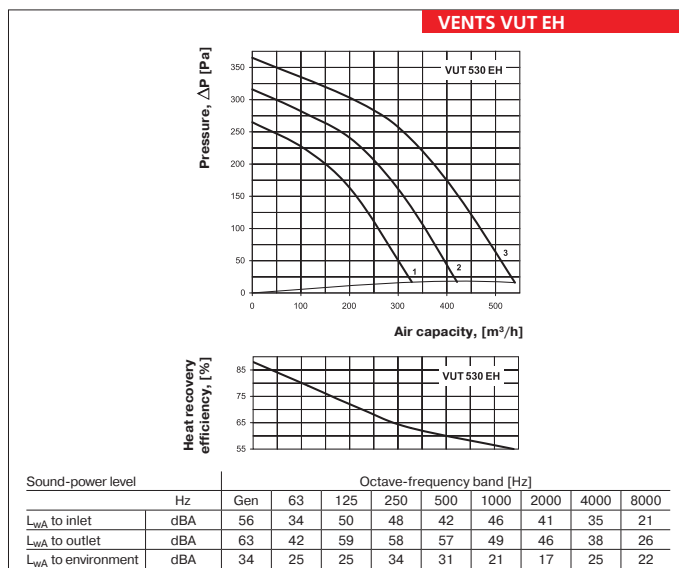
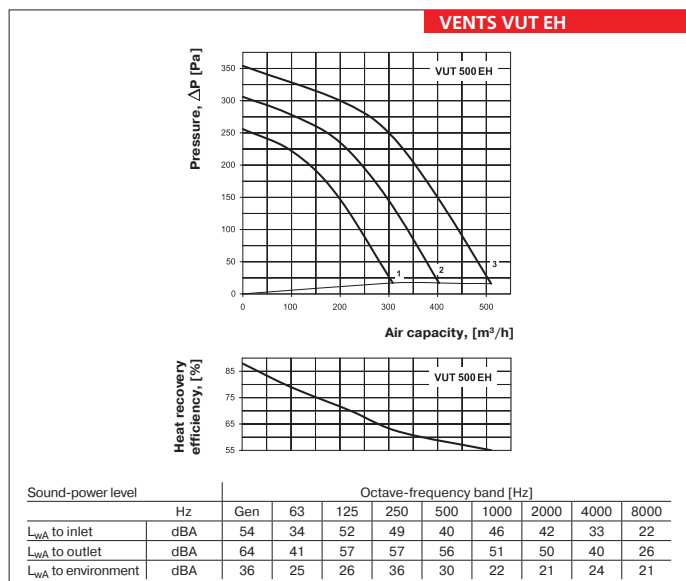
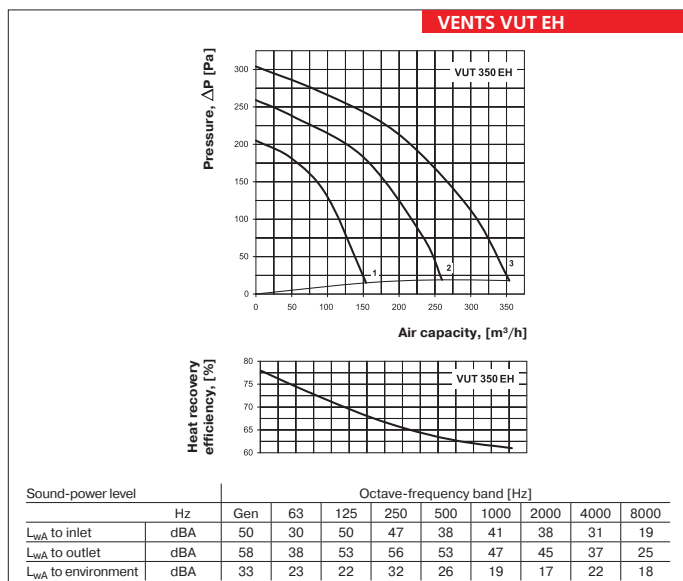

Technical data:

	VUT 600 EH	VUT 800 EH	VUT 800 WH-2 VUT 800 WH-4
Voltage [V / Hz]	1~ 220-240 / 50-60	3~ 400 / 50-60	1~ 220-240 / 50
Maximum fan power [W]	2pcs. x 195		2pcs. x 245
Fan current [A]	2pcs. x 0.86		2pcs. x 1.08
Electric heater power [kW]	4	9.0	-
Electric heater current [A]	17.4	13.0	-
Number of water (glycol) coil rows	-	-	2 or 4
Total unit power [kW]	4.39	9.49	0.49
Total unit current [A]	19.1	15.16	2.16
Air capacity [m ³ /h]	600	800	780
RPM	1350		1650
Noise level at 3m [dBA]	32-48		48
Transported air [°C]	-25 up to +55		-25 up to +45
Casing material	aluzinc		aluzinc
Insulation	25 mm mineral wool		50 mm mineral wool
Extract filter	G4		G4
Supply filter	F7 (EU7)		G4 (F7)*
Connected air duct diameter [mm]	∅200		∅250
Weight [kg]	54	85	88
Heat recovery efficiency	up to 85%		up to 78%
Heat exchanger type	cross-flow type		cross-flow type
Heat exchanger material	aluminum		aluminum

*option

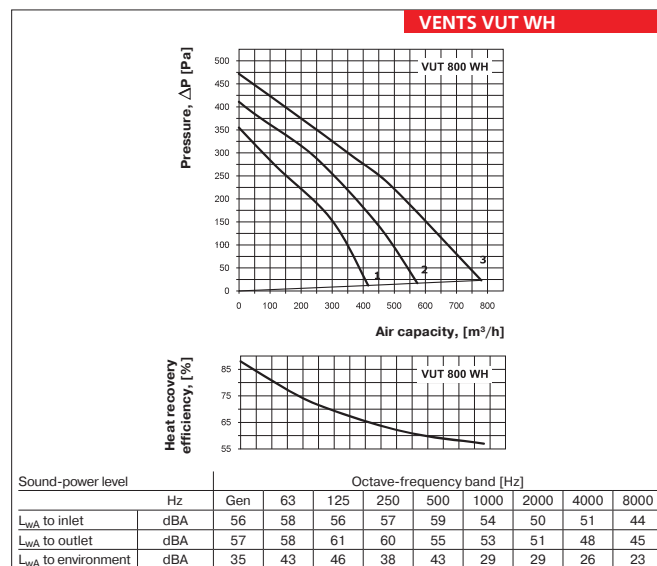
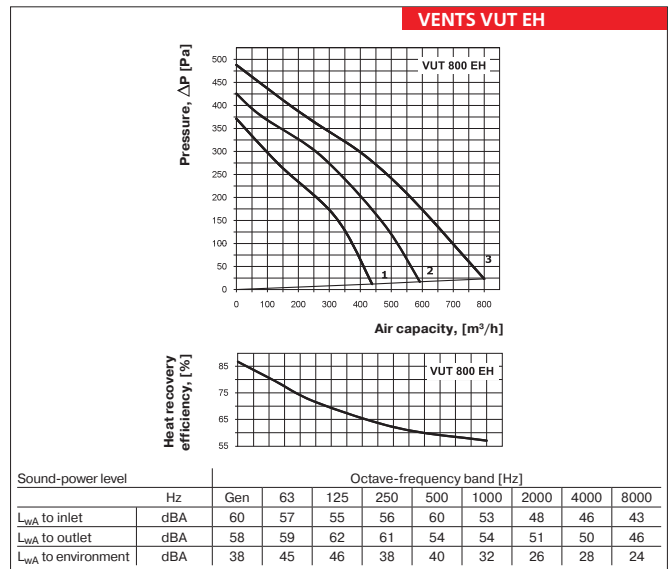
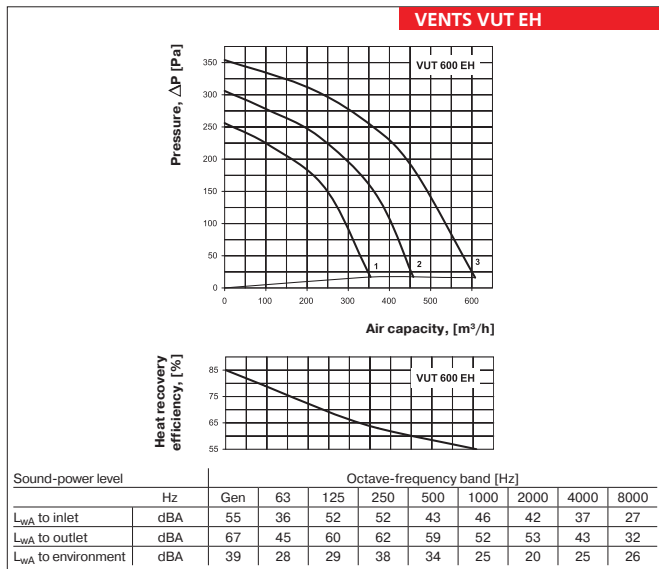

VENTS
 AIR HANDLING UNIT WITH
 VUT EH / WH
 HEAT RECOVERY SERIES

AIR HANDLING UNITS WITH HEAT RECOVERY

Technical data:

	VUT 1000 EH	VUT 1000 WH-2 VUT 1000 WH-4	VUT 1500 EH
Voltage [V / Hz]	3~ 400 / 50	1~ 220-240 / 50	3~ 400 / 50-60
Maximum fan power [W]		2pcs. x 410	2pcs. x 490
Fan current [A]		2pcs. x 1.8	2pcs. x 2.15
Electric heater power [kW]	9.0	-	18.0
Electric heater current [A]	13.0	-	26.0
Number of water (glycol) coil rows	-	2 or 4	-
Total unit power [kW]	9.80	0.82	18.98
Total unit current [A]	16.6	3.6	30.3
Air capacity [m ³ /h]	1200	1100	1750
RPM		1850	1100
Noise level at 3m [dBA]		60	49
Transported air [°C]		-25 up to +40	-25 up to +45
Casing material		aluzinc	aluzinc
Insulation		50 mm mineral wool	50 mm mineral wool
Extract filter		G4	G4
Supply filter		G4 (F7)*	G4 (F7)*
Connected air duct diameter [mm]		∅250	∅315
Weight [kg]	85	88	96
Heat recovery efficiency		up to 78%	up to 77%
Heat exchanger type		cross-flow type	cross-flow type
Heat exchanger material		aluminum	aluminum

*option

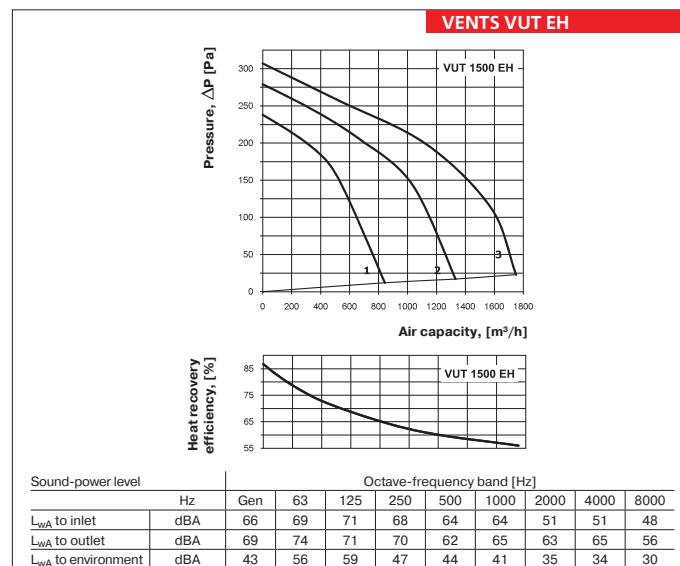
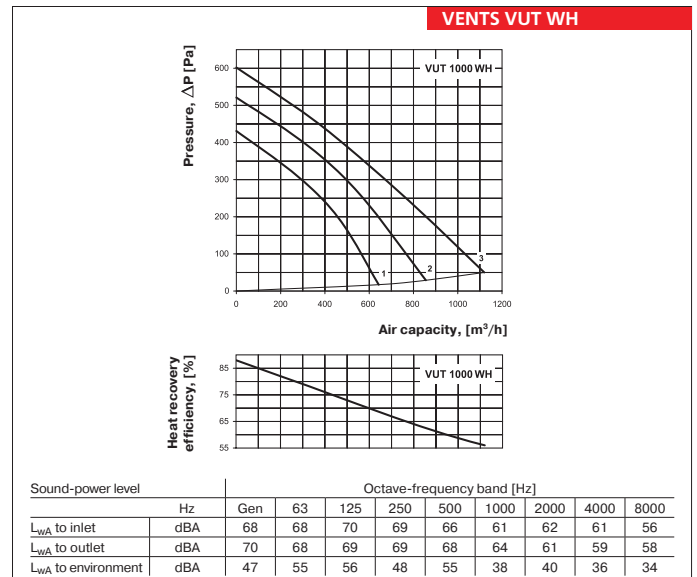
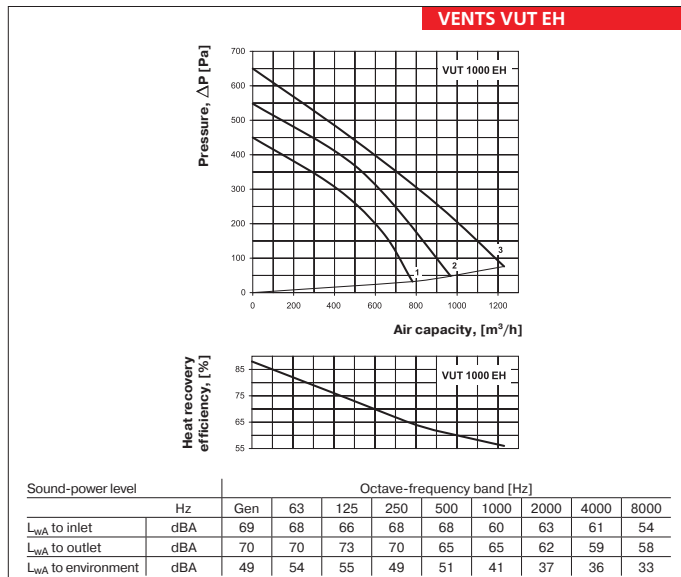

Technical data:

	VUT 1500 WH-2 VUT 1500 WH-4	VUT 2000 EH	VUT 2000 WH-2 VUT 2000 WH-4
Voltage [V / Hz]	1~ 220-240 / 50	3~ 400 / 50-60	1~ 220-240 / 50
Maximum fan power [W]	2pcs. x 490		2pcs. x 650
Fan current [A]	2pcs. x 2.15		2pcs. x 2.84
Electric heater power [kW]	-	18.0	-
Electric heater current [A]	-	26.0	-
Number of water (glycol) coil rows	2 or 4	-	2 or 4
Total unit power [kW]	0.98	19.30	1.30
Total unit current [A]	4.3	31.7	5.68
Air capacity [m ³ /h]	1700	2200	2100
RPM	1100		1150
Noise level at 3m [dBA]	49		65
Transported air [°C]	-25 up to +45		-25 up to +40
Casing material	aluzinc		aluzinc
Insulation	50 mm mineral wool		50 mm mineral wool
Extract filter	G4		G4
Supply filter	G4 (F7)*		G4 (F7)*
Connected air duct diameter [mm]	∅315		∅315
Weight [kg]	99	96	99
Heat recovery efficiency	up to 77%		up to 77%
Heat exchanger type	cross-flow type		cross-flow type
Heat exchanger material	aluminum		aluminum

*option

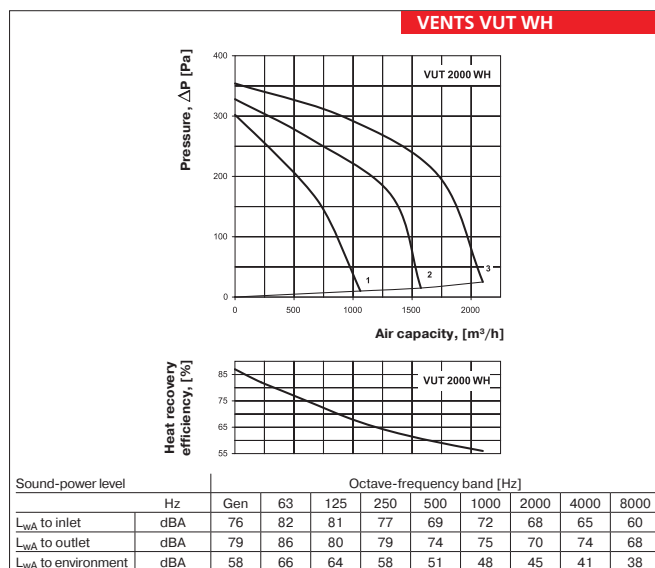
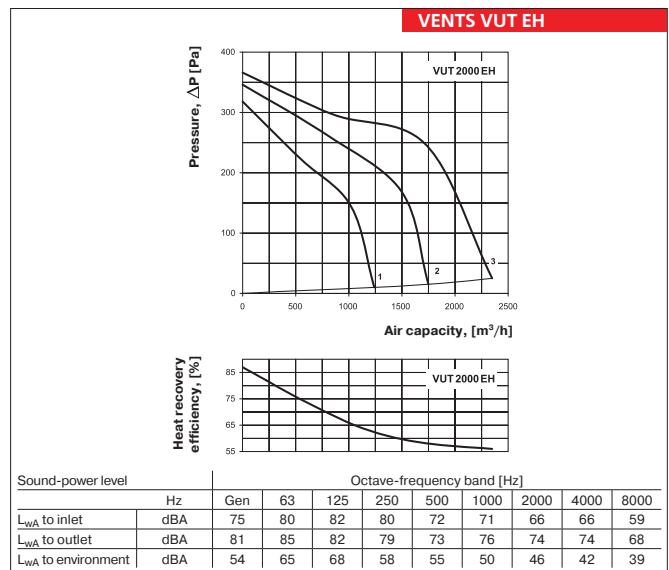
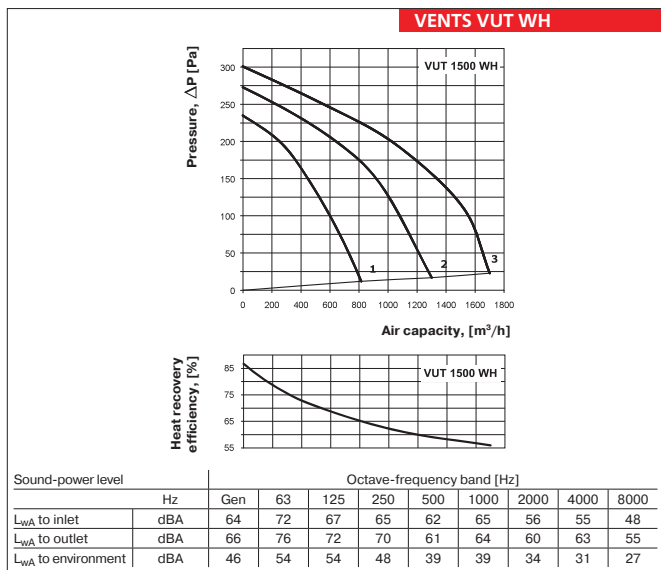

VENTS
 AIR HANDLING UNIT WITH
 VUT EH / WH
 HEAT RECOVERY SERIES

Hot water coil parameters:

VENTS VUT WH

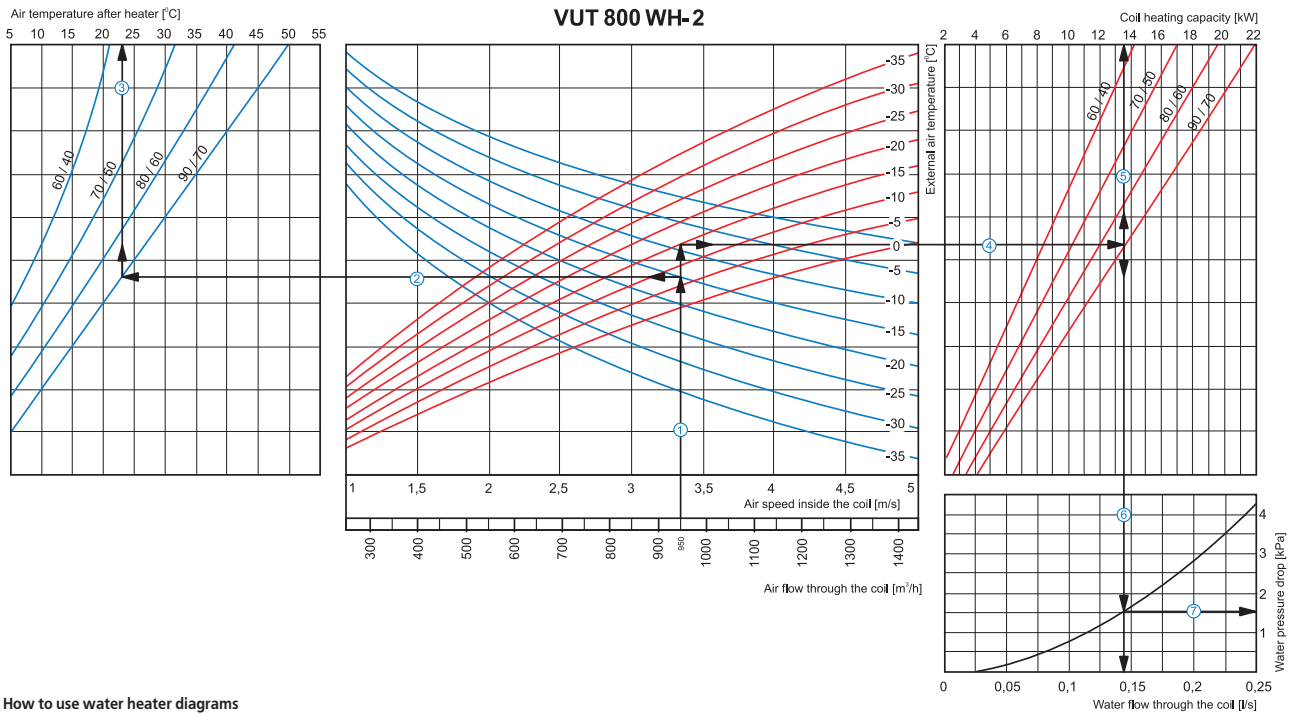

How to use water heater diagrams

System Parameters: Air flow = 950 m³/h. Outside air temper. = -15 °C. Water temperature (in/out) = 90/70 °C

- Air Speed. Starting from 950 m³/h on the air flow scale draw a vertical line ① till the air speed axis which makes about 3.35 m/s.
- Supply air temperature. Prolong the line ① up to the point where it crosses the outside air temperature (blue curve, e.g. -15 °C); then draw a horizontal line ② from this point to the left till crossing water in/out temperature curve (e.g. 90/70 °C). From this point draw a vertical line ③ to the supply air temperature axis on top of the graphic (+23 °C).
- Heating coil capacity. Prolong the line ① up to the point where it crosses the outside air temperature (e.g. -15 °C, red curve) and draw a horizontal line ④ from this point to the right until it crosses water in/out temperature curve (e.g., 90/70 °C), from here draw a vertical line ⑤ up to the scale representing the heating coil capacity (13.5 kW).
- Water flow. Prolong the line ⑤ down to water flow axis at the bottom of the graphic ⑥ (0.14 l/s).
- Water pressure drop. Draw the line ⑦ from the point where the line ⑥ crosses the black curve to the pressure drop axis. (1.5 kPa).

VENTS VUT WH

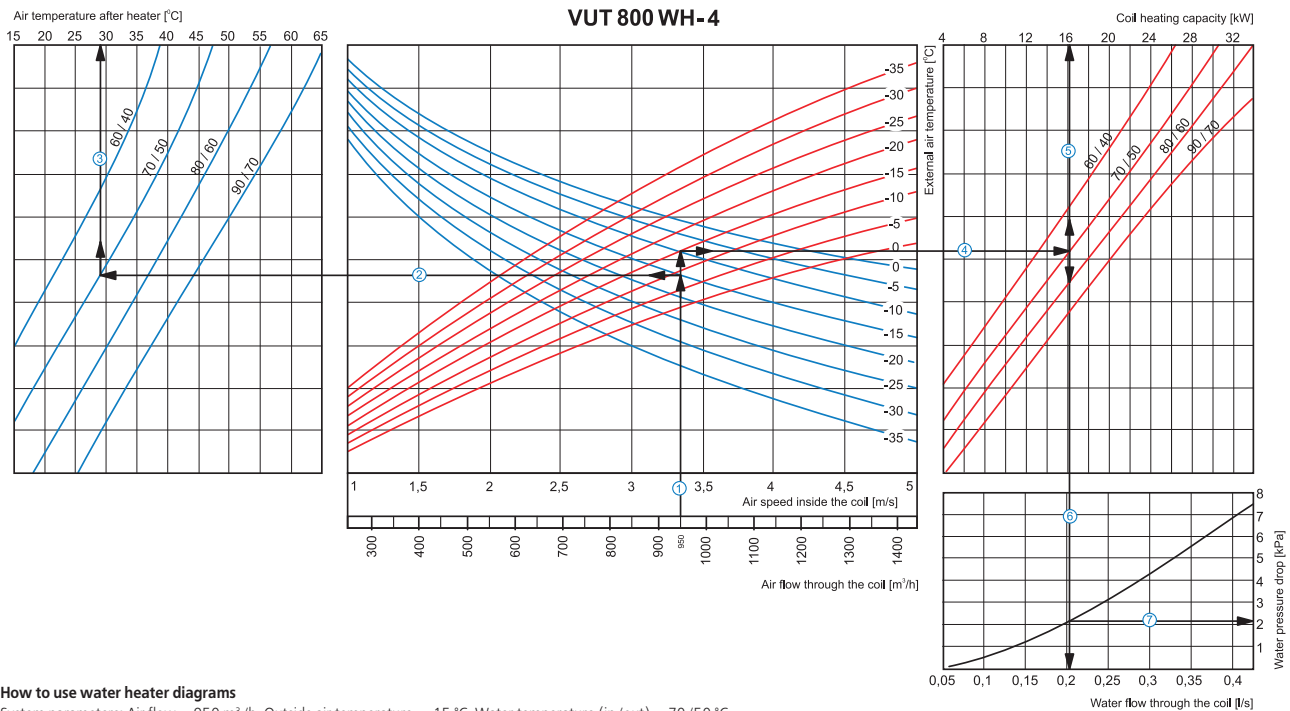

How to use water heater diagrams

System parameters: Air flow = 950 m³/h. Outside air temperature = -15 °C. Water temperature (in/out) = 70/50 °C.

- Air Speed. Starting from 950 m³/h on the air flow scale draw a vertical line ① till the air speed axis which makes about 3.35 m/s.
- Supply air temperature. Prolong the line ① up to the point where it crosses the outside air temperature (blue curve, e.g. -15 °C); then draw a horizontal line ② from this point to the left till crossing water in/out temperature curve (e.g. 70/50 °C). From this point draw a vertical line ③ to the supply air temperature axis on top of the graphic (+29 °C).
- Heating coil capacity. Prolong the line ① up to the point where it crosses the outside air temperature (e.g. -15 °C, red curve) and draw a horizontal line ④ from this point to the right until it crosses water in/out temperature curve (e.g., 70/50 °C), from here draw a vertical line ⑤ up to the scale representing the heating coil capacity (16.0 kW).
- Water flow. Prolong the line ⑤ down to water flow axis at the bottom of the graphic ⑥ (0.2 l/s).
- Water pressure drop. Draw the line ⑦ from the point where the line ⑥ crosses the black curve to the pressure drop axis. (2.1 kPa).

Hot water coil parameters:

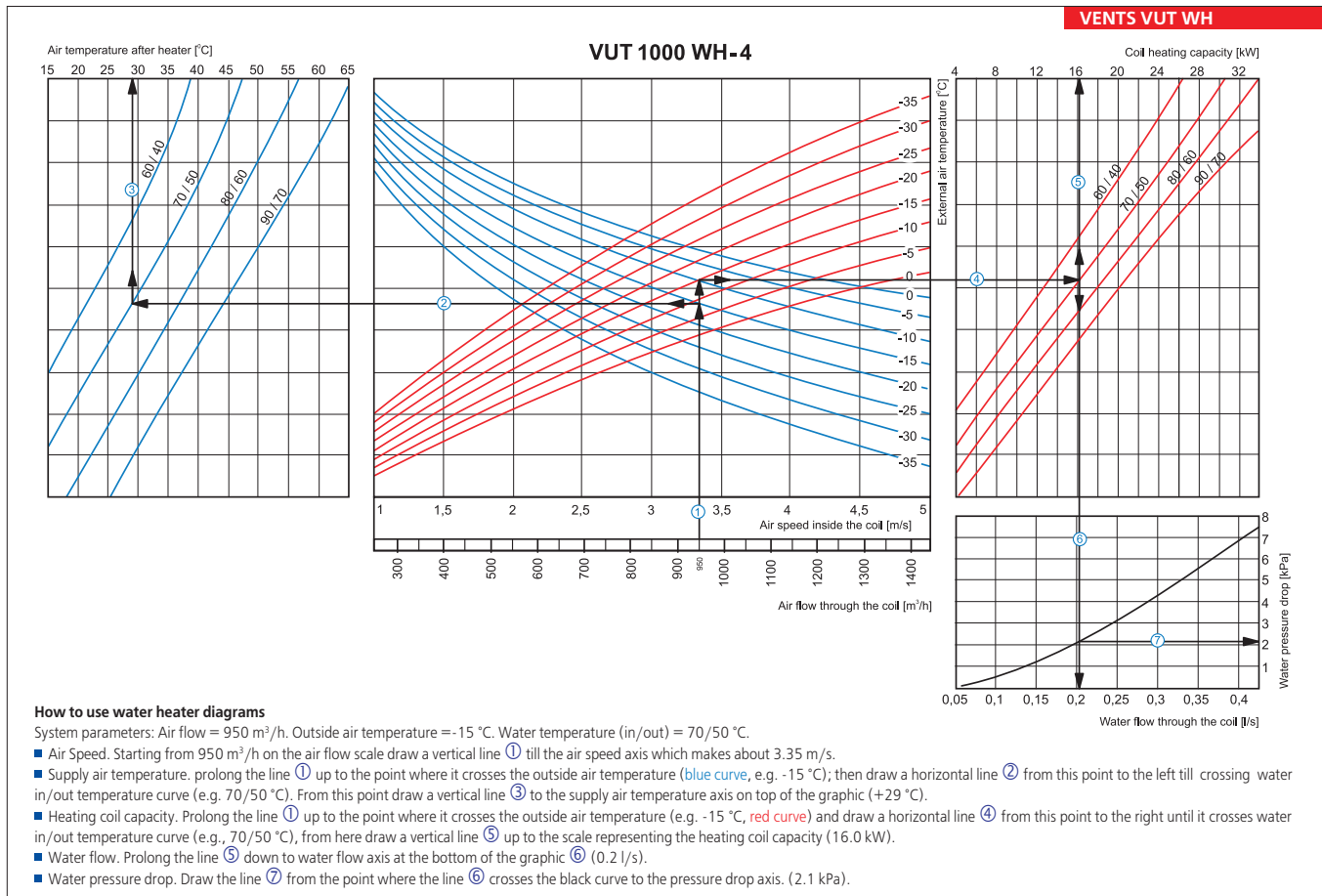
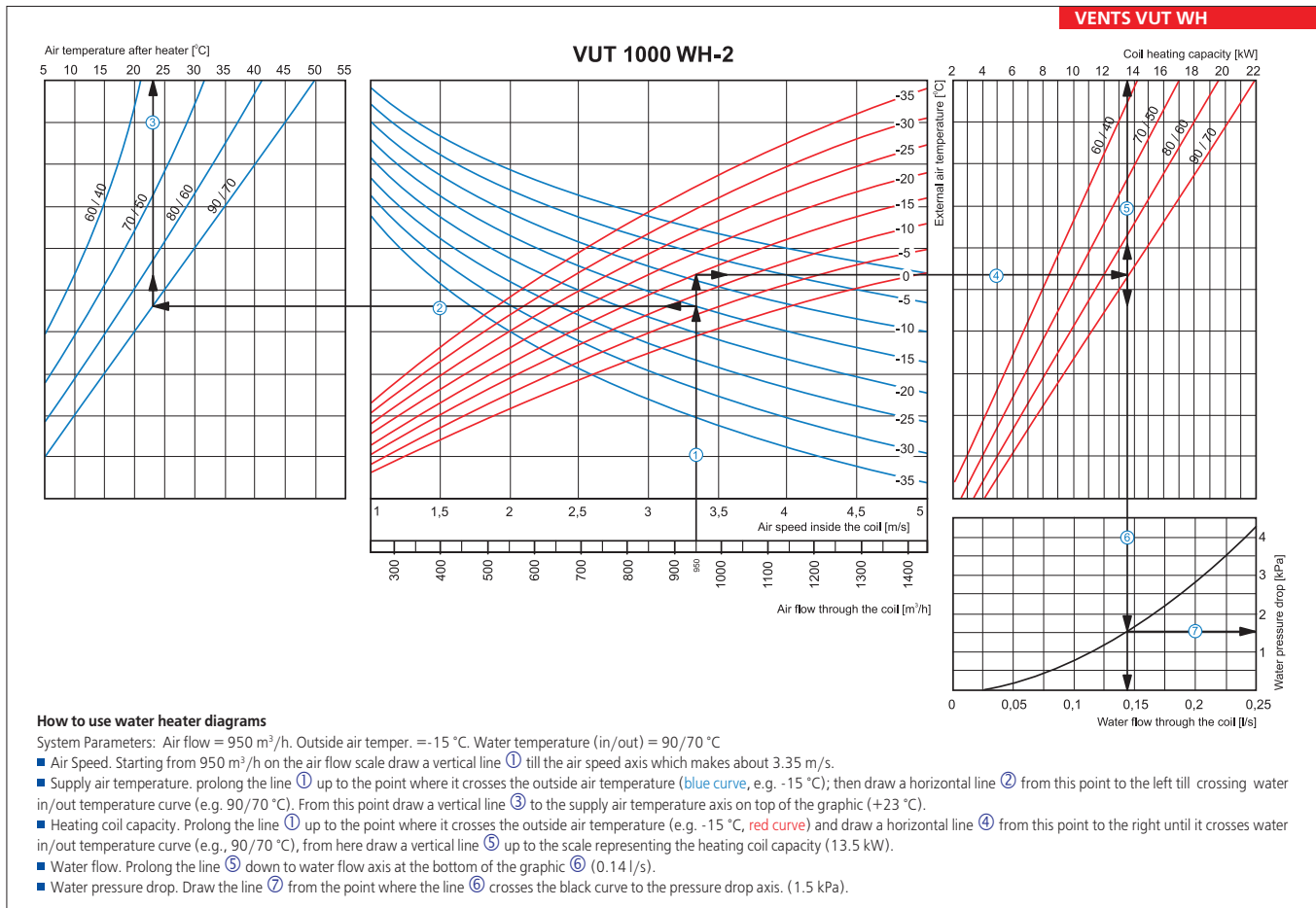

VENTS
AIR HANDLING UNIT WITH
HEAT RECOVERY SERIES
VUT EH / WH

Hot water coil parameters:

VENTS VUT WH

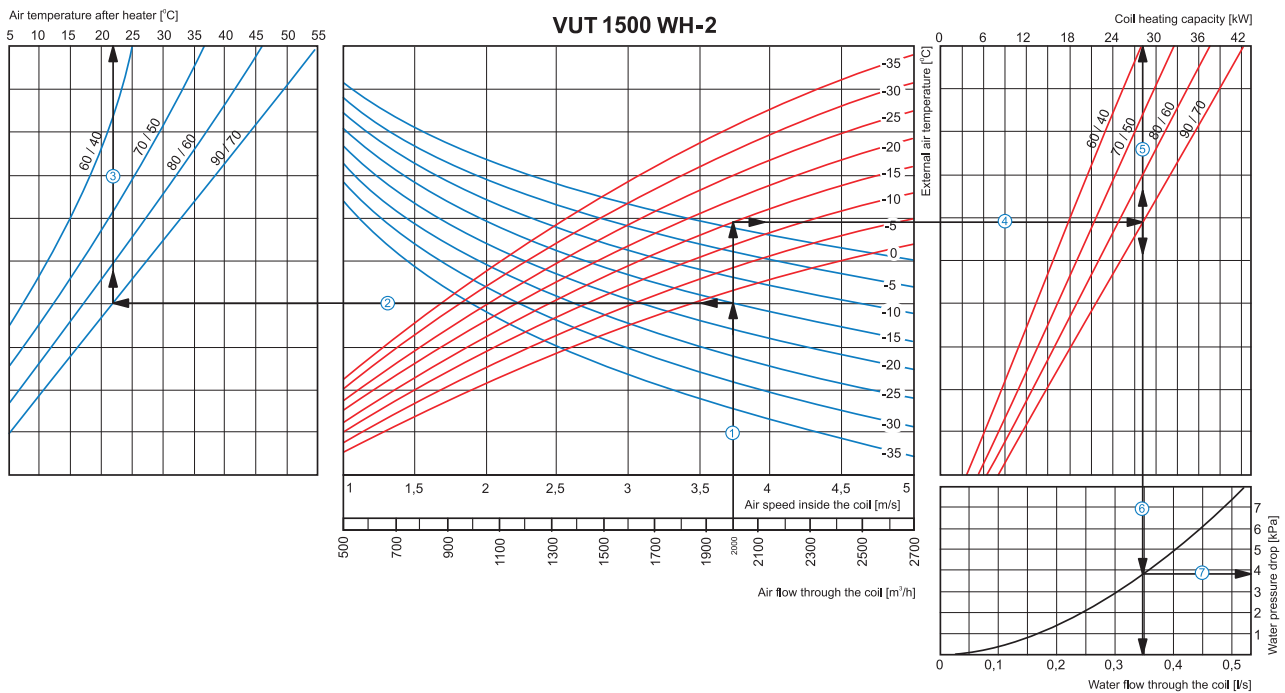

How to use water heater diagrams

System Parameters: Air flow = 2000 m³/h. Outside air temperature = -15 °C. Water temperature (in/out) = 90/70 °C.

- **Air Speed.** Starting from 2000 m³/h on the air flow scale draw a vertical line ① till the air speed axis. (3.75 m/s).
- **Supply air temperature.** Prolong the line ① up to the point where it crosses the outside air temperature (blue curve, e.g. -15 °C); then draw a horizontal line ② from this point to the left till crossing water in/out temperature curve (e.g. 90/70 °C). From this point draw a vertical line ③ to the supply air temperature axis on top of the graphic (+22 °C).
- **Heating coil capacity.** Prolong the line ① up to the point where it crosses the outside air temperature (e.g. -15 °C, red curve) and draw a horizontal line ④ from this point to the right until it crosses water in/out temperature curve (e.g., 90/70 °C), from here draw a vertical line ⑤ up to the scale representing the heating coil capacity (28.0 kW).
- **Water flow.** Prolong the line ⑤ down to water flow axis at the bottom of the graphic ⑥ (0.35 l/s).
- **Water pressure drop.** Draw the line ⑦ from the point where the line ⑥ crosses the black curve to the pressure drop axis. (3.8 kPa).

VENTS VUT WH

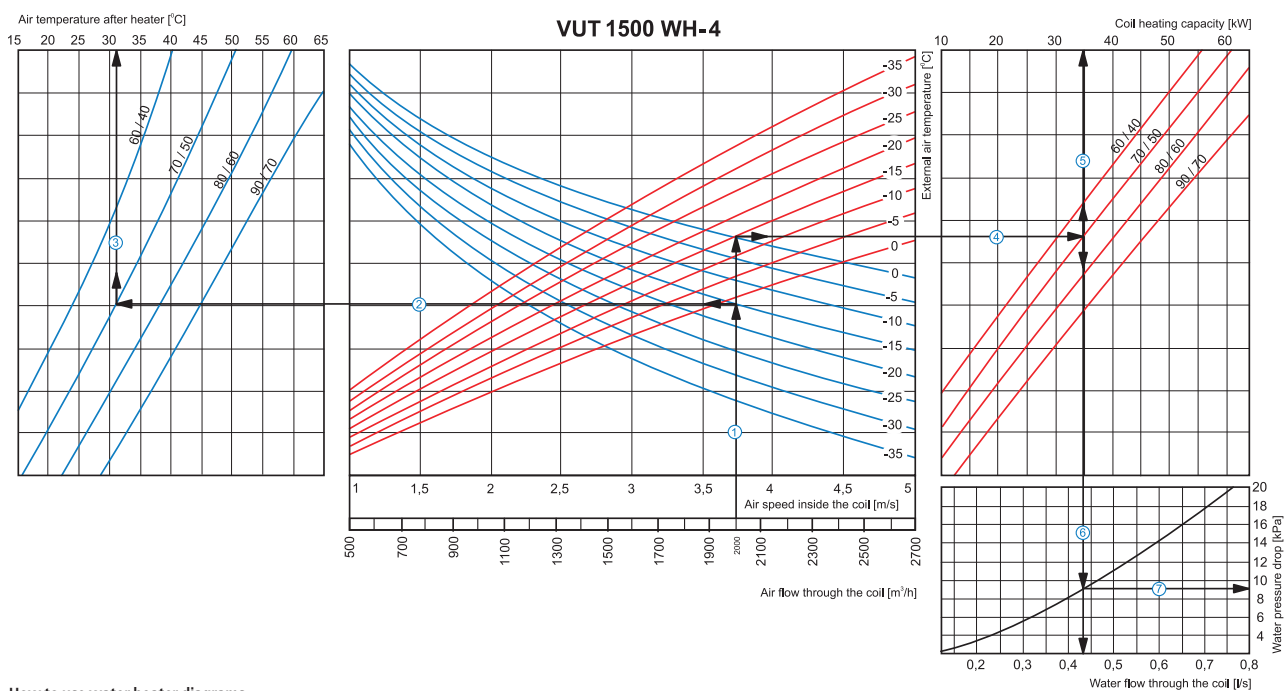

How to use water heater diagrams

System Parameters: Air flow = 2000 m³/h. Outside air temperature = -15 °C. Water temperature (in/out) = 70/50 °C.

- **Air Speed.** Starting from 2000 m³/h on the air flow scale draw a vertical line ① till the air speed axis which makes about 3.75 m/s.
- **Supply air temperature.** Prolong the line ① up to the point where it crosses the outside air temperature (blue curve, e.g. -15 °C); then draw a horizontal line ② from this point to the left till crossing water in/out temperature curve (e.g. 70/50 °C). From this point draw a vertical line ③ to the supply air temperature axis on top of the graphic (+31 °C).
- **Heating coil capacity.** Prolong the line ① up to the point where it crosses the outside air temperature (e.g. -15 °C, red curve) and draw a horizontal line ④ from this point to the right until it crosses water in/out temperature curve (e.g., 70/50 °C), from here draw a vertical line ⑤ up to the scale representing the heating coil capacity (35.0 kW).
- **Water flow.** Prolong the line ⑤ down to water flow axis at the bottom of the graphic ⑥ (0.43 l/s).
- **Water pressure drop.** Draw the line ⑦ from the point where the line ⑥ crosses the black curve to the pressure drop axis. (9.0 kPa).

Hot water coil parameters:

VENTS VUT WH

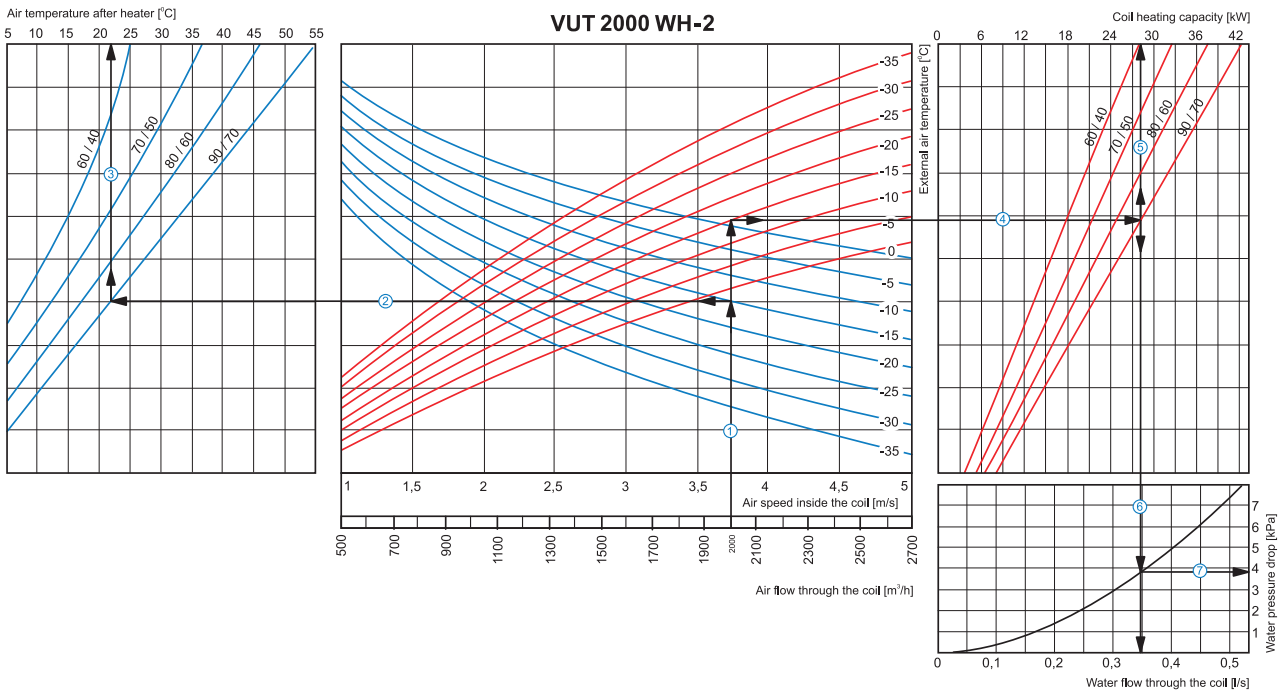

How to use water heater diagrams

System Parameters: Air flow = 2000 m³/h. Outside air temperature = -15 °C. Water temperature (in/out) = 90/70 °C.

- Air Speed. Starting from 2000 m³/h on the air flow scale draw a vertical line ① till the air speed axis. (3.75 m/s).
- Supply air temperature. Prolong the line ① up to the point where it crosses the outside air temperature (blue curve, e.g. -15 °C); then draw a horizontal line ② from this point to the left till crossing water in/out temperature curve (e.g. 90/70 °C). From this point draw a vertical line ③ to the supply air temperature axis on top of the graphic (+22 °C).
- Heating coil capacity. Prolong the line ① up to the point where it crosses the outside air temperature (e.g. -15 °C, red curve) and draw a horizontal line ④ from this point to the right until it crosses water in/out temperature curve (e.g., 90/70 °C), from here draw a vertical line ⑤ up to the scale representing the heating coil capacity (28.0 kW).
- Water flow. Prolong the line ⑤ down to water flow axis at the bottom of the graphic ⑥ (0.35 l/s).
- Water pressure drop. Draw the line ⑦ from the point where the line ⑥ crosses the black curve to the pressure drop axis. (3.8 kPa).

VENTS VUT WH

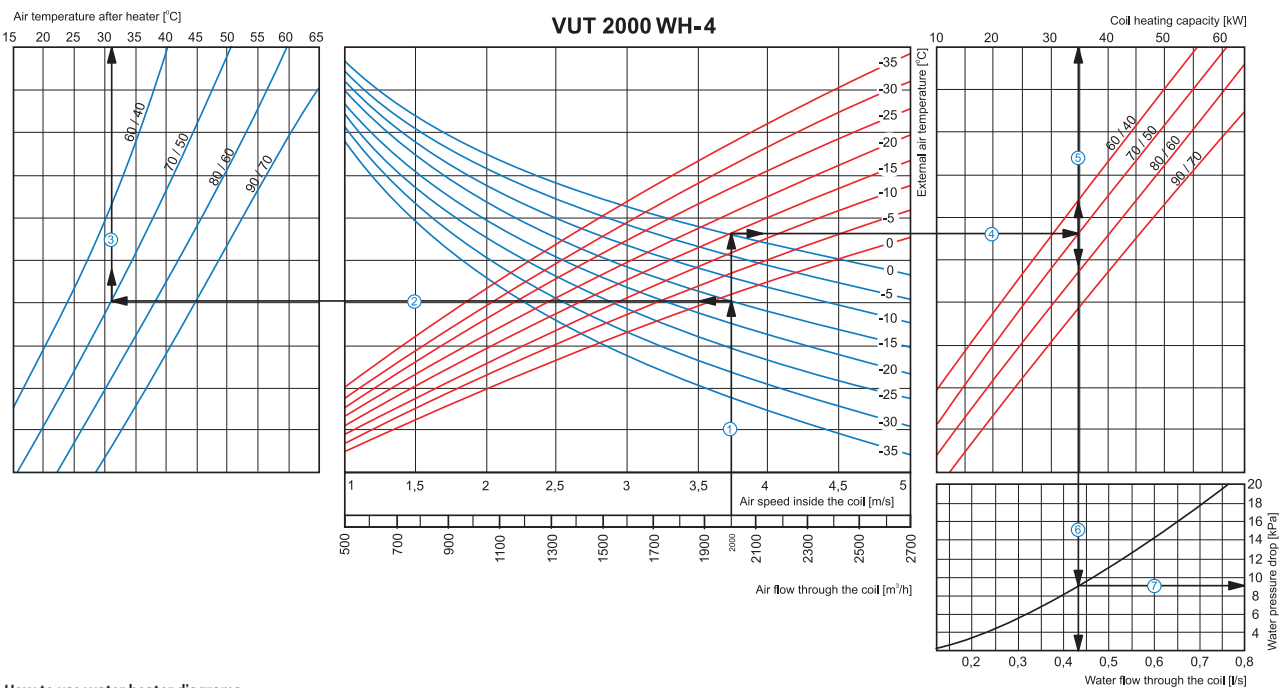

How to use water heater diagrams

System Parameters: Air flow = 2000 m³/h. Outside air temperature = -15 °C. Water temperature (in/out) = 70/50 °C.

- Air Speed. Starting from 2000 m³/h on the air flow scale draw a vertical line ① till the air speed axis which makes about 3.75 m/s.
- Supply air temperature. Prolong the line ① up to the point where it crosses the outside air temperature (blue curve, e.g. -15 °C); then draw a horizontal line ② from this point to the left till crossing water in/out temperature curve (e.g. 70/50 °C). From this point draw a vertical line ③ to the supply air temperature axis on top of the graphic (+31 °C).
- Heating coil capacity. Prolong the line ① up to the point where it crosses the outside air temperature (e.g. -15 °C, red curve) and draw a horizontal line ④ from this point to the right until it crosses water in/out temperature curve (e.g., 70/50 °C), from here draw a vertical line ⑤ up to the scale representing the heating coil capacity (35.0 kW).
- Water flow. Prolong the line ⑤ down to water flow axis at the bottom of the graphic ⑥ (0.43 l/s).
- Water pressure drop. Draw the line ⑦ from the point where the line ⑥ crosses the black curve to the pressure drop axis. (9.0 kPa).